



VRX21 • VRX31 • VRX41 • VRX51 • VRX61 • VRX71

VIBRATING PROBE

Operating Instructions
Please read carefully

BinMaster

Division of Garner Industries
2021 Transformation Dr Ste 2230
Lincoln, NE 68508-9741
(402) 434-9102

TABLE OF CONTENTS

General Specifications.....	3
Safety Summary	4
1.0 Introduction.....	5
2.0 Applications	5
3.0 Versions.....	5
3.1 Sediment Model.....	6
3.2 High Temperature Model	6
3.3 Super High Temperature Model.....	6
3.4 Hanging Probe Details VRX51	6
4.0 Installation	7
4.1 Location and Mounting	7
Figure 1 Location Diagram	8
Figure 2 Mounting Orientation Guidelines	8
4.2 Input Power and Field Wiring	10
Figure 3 VRX Models & Mounts	10
5.0 Relay Contacts	11
5.1 Activation Delay Settings	11
6.0 Light Ring Status	11
8.0 Remote Electronics Installation ..	12
9.0 Terms & Conditions - Warranty	13
9.1 Customer Service & Tech Support	13
10.0 Disposal.....	13
Spec Drawing - VRX21.....	14
Spec Drawing - VRX31.....	15
Spec Drawing - VRX41.....	16
Spec Drawing - VRX51.....	17
Spec Drawing - VRX61.....	18
Spec Drawing - VRX71.....	19

GENERAL SPECIFICATIONS

Power supply:	24 VDC or 115/230 VAC, Model Dependent
	24 VDC 1.5 VA
	115/230 VAC 5 VA
Ambient temperature (Electronics):	-4° F to +140° F (-20° C to +60° C)
Process temperature	
Standard Probe	-4° F to +176° F (-20° C to +80° C)
HT Probe	-4° F to +284° F (-20° C to +140° C)
VRX61, VRX71	-4° F to +500° F (-20° C to +260° C)
 Enclosure:	Powdercoated: NEMA Type 4X
Relay output:	DPDT contacts, 5 Amps 250 VAC
Mounting (Model Dependent):	1.25" NPT
	1.5" NPT
	2" Tri-clamp
Conduit entries:	0.75" NPT
Minimum material density:	1.9 lb/cu ft (30 g/liter) for all above models

SAFETY SUMMARY

Review the safety precautions to avoid injury and prevent damage to equipment.

The product should be installed, commissioned, and maintained by qualified, authorized personnel only.

Install according to instructions and comply with all National and Local codes.

Use electrical wire that is sized and rated for the maximum voltage and current of the application. Properly ground the enclosure to an adequate earth ground.

Observe terminal and relay contact ratings on the nameplate and in the installation manual.

Ensure the enclosure cover is in place and secured tightly during normal operation. In potentially wet environments, thoroughly seal all conduit entries.

If this product is used in a manner not specified by the manufacturer safety protection could be compromised.

Safety Terms and Symbols



WARNING: Warning statements identify conditions or practices that could result in injury or loss of life. Risk of electrical shock.



CAUTION: Caution statements identify conditions or practices that could result in damage to this product or other property.

1.0 INTRODUCTION

The BinMaster VRX vibrating probes are point level controls used to detect the presence or absence of granular or powdered material. The vibrating probe operates by exciting the blade of unit to cause it to vibrate at its mechanical resonance frequency of about 290 Hz. When material covers the blade of the probe, the vibration stops. This is sensed by the electronic circuitry causing the relay contacts to change status.

When the blade becomes uncovered, the vibration will restart and the relay contacts will change back. Since only the end of the vibrating blade is sensitive and not the base, buildup on the vessel wall has no influence on the sensor. The shape of the blade and its vibration have a self-cleaning effect.

2.0 APPLICATIONS

The BinMaster VRX vibrating probe can be used in bins, silos, and hoppers to detect many different granular or powdered materials. The following list shows some of these materials:

Animal feed	Powdered cellulose
Beans	Powdered clay
Chalk	Powdered milk
Coffee beans	Salt
Coffee (freeze-dried)	Soda ash
Coffee (ground)	Soot (dry pellets)
Flour	Spices
Foundry sand	Styrene chips
Frozen potato chips	Sugar
Glass (finely ground)	Sweets
Granular plastics	Styrofoam™
Gravel	Tea (leaf)
Peanuts	Tobacco
Polystyrene powder	Wood shavings

3.0 VERSIONS

The BinMaster VRX is available in 6 different versions:

- VRX21 - 1.25" & 1.5" NPT mount, standard insertion length 7.5" (190mm)
- VRX31 - 2" sanitary Tri-clamp, insertion length 11.81" up to 78.74"
- VRX41 - 1.25" & 1.5" NPT mount, with threaded pipe extension for insertion length from 13" up to 13 ft.
- VRX51 - 1.5" NPT mount, with cable extension for insertion length from 19" up to 19.5 ft.
- VRX61 - 1.5" NPT mount, insertion length 7.25"
- VRX71 - 1.5" NPT mount, insertion length 10.25" up to 160"

3.1 SEDIMENT MODEL

BinMaster VRX Sediment is a specialized configuration of the VRX21/VRX41 level control instrument. It is designed to detect the level of solid material that has settled in water.

A typical application is the detection of sand in front of pumping systems.

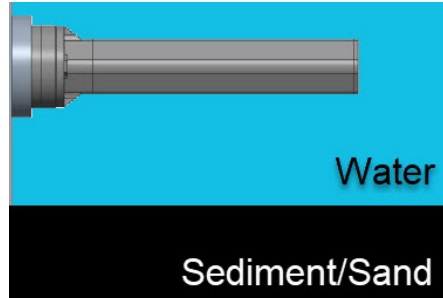

SPECIAL INSTRUCTIONS FOR SEDIMENT MODEL VIBRATING PROBE

General:

This special sediment model vibrating probe is tuned to work (vibrate) in water. This means that it may not vibrate in air which would result in a covered indication. To test the sediment model vibrating probe, you have to put the vibrating blade into water. The sediment model is not usable for detecting liquids or solids in air. The blade of the BinMaster VRX Sediment must have a distance of at least 4" (100mm) to the container wall. If the blade gets closer than this to the container wall, then the vibration could be damped by reflections of the container wall.

Sensitivity:

This setting depends on the weight of the settled material and the water/material mixture.

Hi, Higher Sensitivity: The vibration gets damped earlier. Depending on the density of the material, the relay will switch when the water/material mixture on top of the settlement just reaches the vibrating blade.

Lo, Lower Sensitivity: The vibration gets damped later, to allow the vibrating blade to be fully covered by settled material.

3.2 High Temperature Model

The VRX21 and 41 have an optional higher operating temperature probe available, known as an "HT" probe. This probe is the same mechanical device with higher operating temperature internals. This probe has an upper process temperature limit of 284°F. Probes with even higher operating temperatures are available on the VRX61 and VRX71.

3.3 Super High Temperature Model, VRX61 and 71

The VRX61 and VRX71 probes are specially engineered for extreme heat environments and are rated to function at up to 500°F process temp. They are functionally identical to the other probes but are built to withstand higher temperatures.

3.4 Hanging Probe Details VRX51

The VRX51 is a special model of VRX that hangs into a tank or process by a steel cable. It is functionally similar to the other VRX models, but considerations need to be made to ensure proper operation and longevity of the probe. The probe should only be able to touch material being measured from its hanging location. Especially ensure that the probe cannot impact on or rub against any metal. Consider material height changes and flow characteristics when making this judgment.

Function:

A piezo system brings the probe to vibrate at its resonant frequency. The vibrating system is tuned to work in water. If solid material covers the probe, it damps the vibration. An electronics circuit switches a binary output signal. When the probe gets uncovered, it starts vibrating again and the output switches back.

4.0 INSTALLATION

4.1 Location and Mounting

Figure 1 shows the typical installation possibilities of the BinMaster VRX units.

The BinMaster VRX21 is installed by screwing the male mounting threads into a 1.25" or 1.5" NPT coupling or mounting flange. Use a 2" (50mm) wrench to tighten the unit into the mounting socket.

The VRX31 is installed by passing the vibrating probe blade portion through the mounting hole, then aligning the tri-clamp gasket (not provided) and devices integrated 2" tri-clamp into the vessel's tri-clamp ferrule mount.

The VRX41 is installed by passing the vibrating probe blade portion through the mounting hole, then screwing the device's male mounting threads into a 1.5" NPT coupling or mounting flange. Use a wrench on the hex flats to tighten the unit into the mounting coupling or flange.

The VRX51 is installed by passing the vibrating rod blade portion and cable through the mounting hole, then screwing the device's male mounting threads into a 1.5" NPT coupling or mounting flange. Use a 1-11/16 inch wrench to tighten the unit into the mounting coupling or flange.

The VRX61 is installed by screwing the male mounting threads into a 1.5" NPT coupling or mounting flange. Use a 2" (50mm) wrench to tighten the unit into the mounting socket.

The VRX71 is installed by passing the vibrating probe blade portion through the mounting hole, then screwing the device's male mounting threads into a 1.5" NPT coupling or mounting flange. Use a 2" (50mm) wrench to tighten the unit into the mounting coupling or flange.

If side mounting any VRX, it must be turned until the blade is vertically-oriented, so that material can flow freely over the blade and does not rest on it causing false alarms. Use the round indentation on the 2" hex collar to identify the blade orientation. When the indentation is up the blade is oriented correctly. Refer to Figure 1 for a view of blade orientation.

WARNING: Do not screw in by turning the enclosure housing!

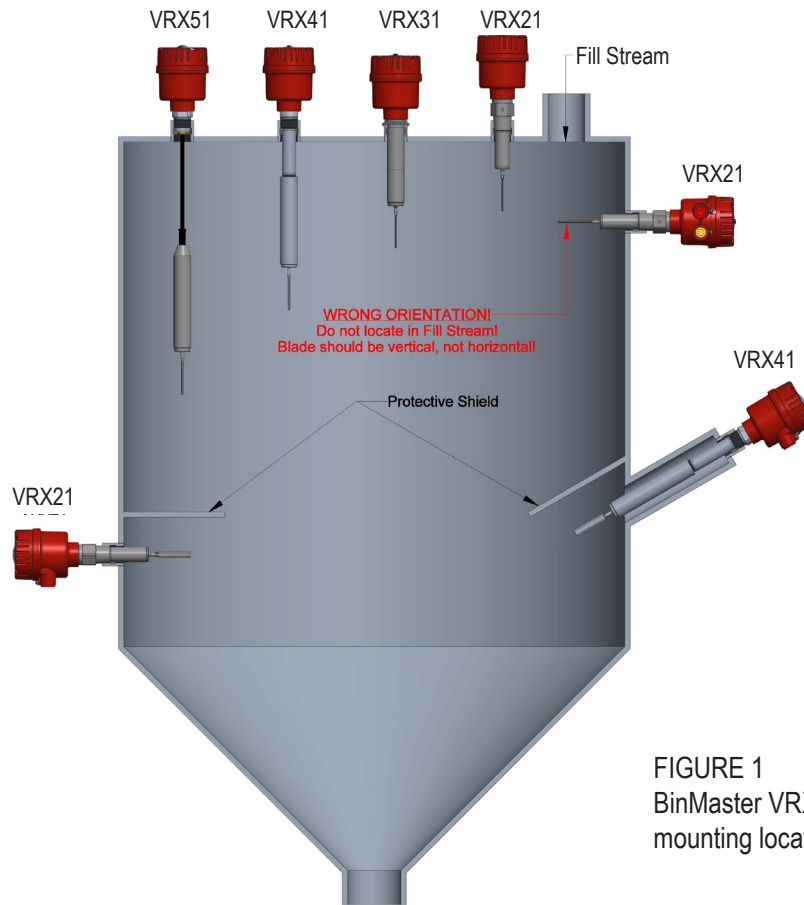

FIGURE 1
BinMaster VRX series
mounting locations

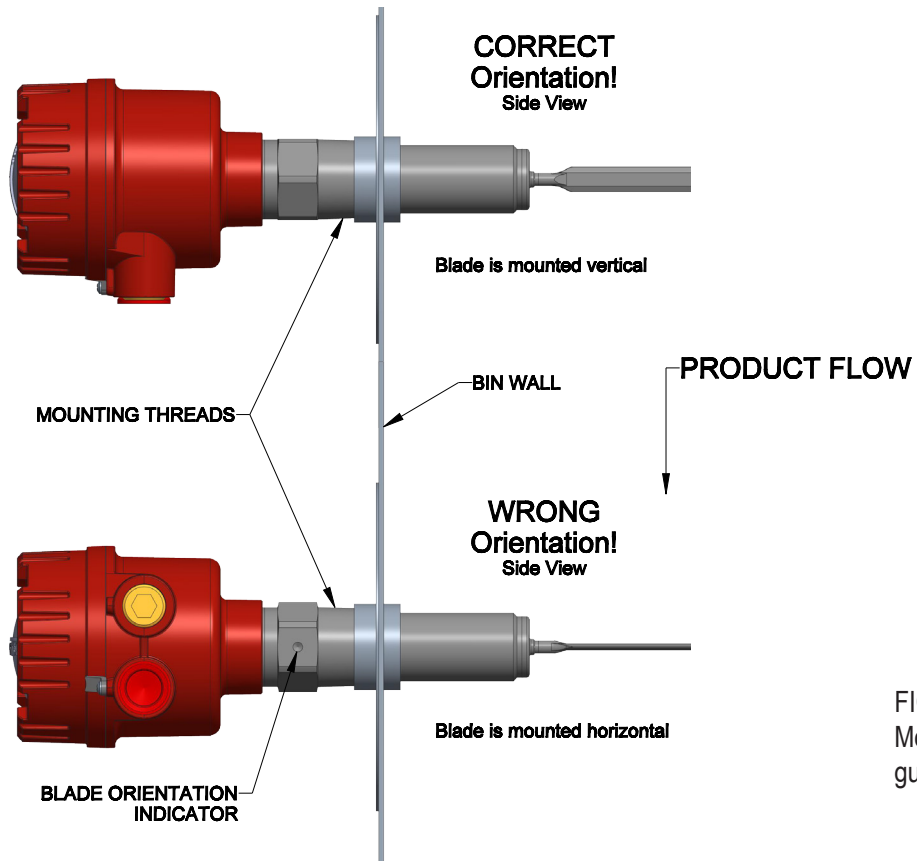
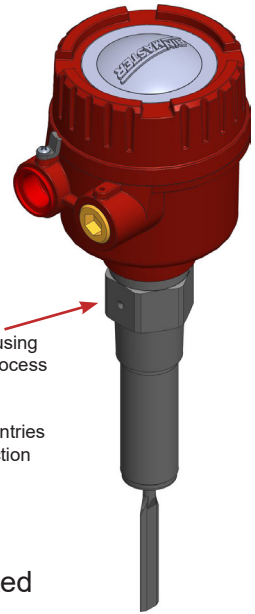

FIGURE 2
Mounting orientation
guidelines

MOUNTING

Use the hex flats provided on the process connection for tightening the instrument into the mounting coupler or mounting plate.

The enclosure can be rotated 270 degrees after the process connection is tight. NOTE: For side mount application, rotate enclosure conduit entries DOWN after the process connection is tight.



Note: Tighten/loosen only using the flats provided on the process connection.

Rotate enclosure conduit entries down after process connection is tight.

MOUNTING ORIENTATION (Side Mount)

To prevent moisture or humidity from entering the unit, the rotary MUST be mounted with the conduit entries facing down.

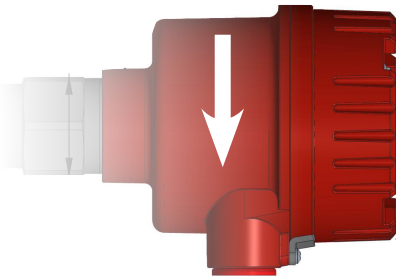

Conduit Seal

When installing the rotary in environments where moisture or moist air may enter the unit through the electrical conduit, the conduit openings should be sealed with an appropriate duct seal compound or putty.

Mounting Plates

Mounting plates are needed when a completely assembled VRX is mounted on the bin wall from the outside. Cut a 5.5" hole in the bin. Drill six bolt holes around the hole to match the mounting plate. Bolt the plate, with the unit attached, into place. Mounting plates are available in carbon or stainless steel

Full Coupling

For use with all VRX level controls. Full coupling is used for top of bin installations where shaft extensions and shaft guards are used.

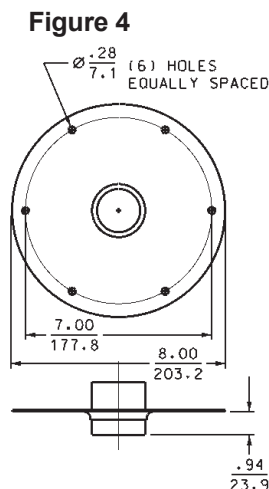

Half Coupling

For use with all VRX level controls. Half coupling is used primarily for side of bin installations.

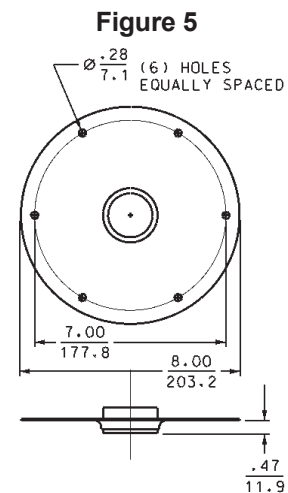

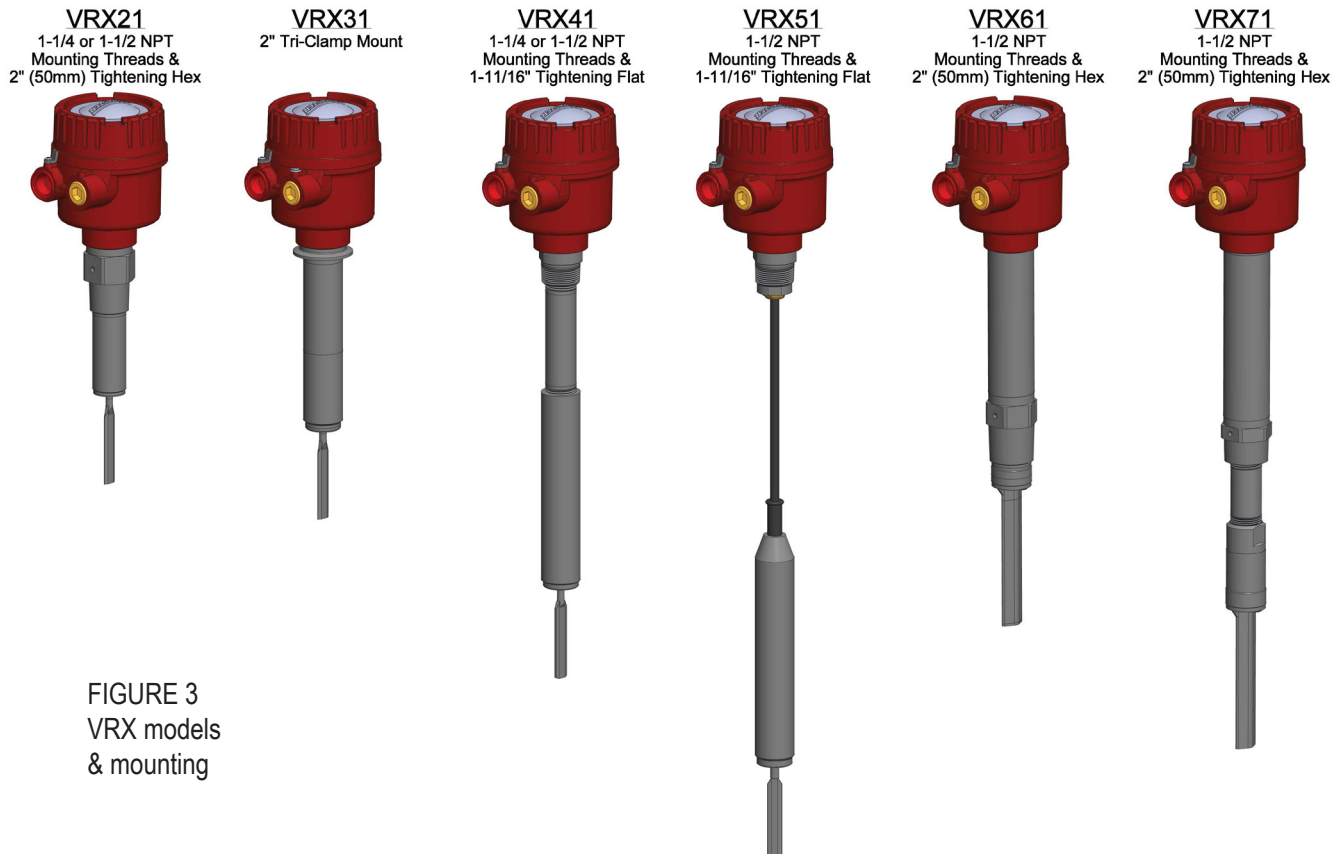

FIGURE 3
VRX models
& mounting

4.2 INPUT POWER AND FIELD WIRING

BinMaster VRX units have a 115/230 VAC/VDC model and a low voltage 24 VDC model.

NOTE: Verify the voltage input specifications on the nameplate before wiring.

The terminals on the circuit board for the power supply and the relay contacts allow for a maximum conductor size of 12 AWG. An equipment grounding connection (earth ground) should be supplied to the unit for safety. See the diagram below for terminal and component identification. Field wiring should conform to all national and local electrical codes and any other agency or authority having jurisdiction over the installation.

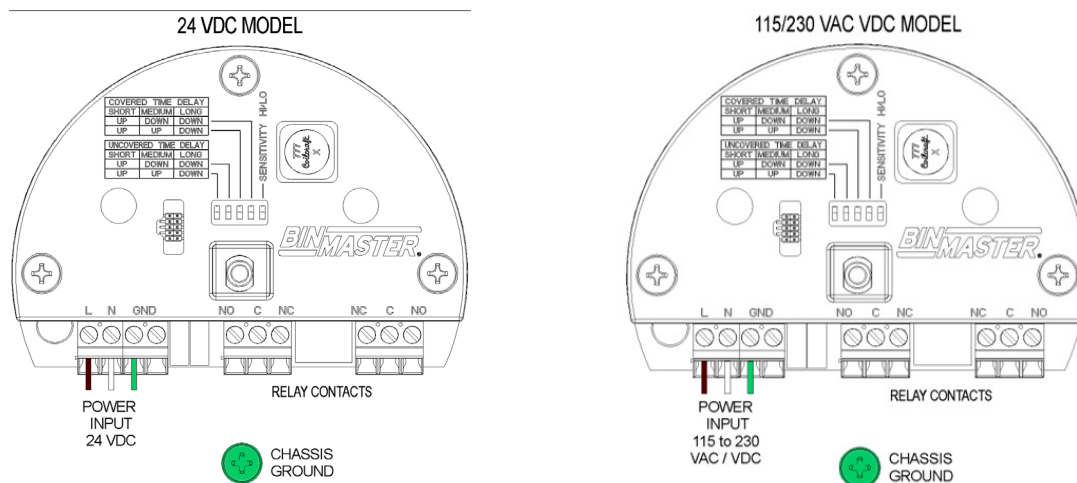

5.0 RELAY CONTACTS

5.1 Activation delay settings

There is a short delay from when the probe detects that it is covered to when the probe indicates that it is covered, both with regard the light ring and the relay output. This delay is configurable to allow for both process flexibility and incidental contact compensation. The same is also true for transitioning to an uncovered state. There is also a short delay ~1 second from when the probe is uncovered to when it indicates as such. This delay is also configurable in the same manner.

The delays are configured by adjusting the positions of the dip switches inside the lid of the sensor. The positions required for various delays are indicated by the artwork on the top left of the board cover, as shown below. The estimated delay times are listed below as well. These vary slightly as the electrical components are affected by ambient temperature. Short: ~1s Medium: ~6s Long: ~20s.

The sensor will come from the factory preset to the short delay for both covered and uncovered.

5.2 There are 2 DPDT Relay outputs used to signal the condition of the sensing probe, either COVERED or UNCOVERED depending on whether material in the vessel has covered the sensing probe. Each relay has C (common), NO (normally open) and NC (normally closed) wiring terminals.

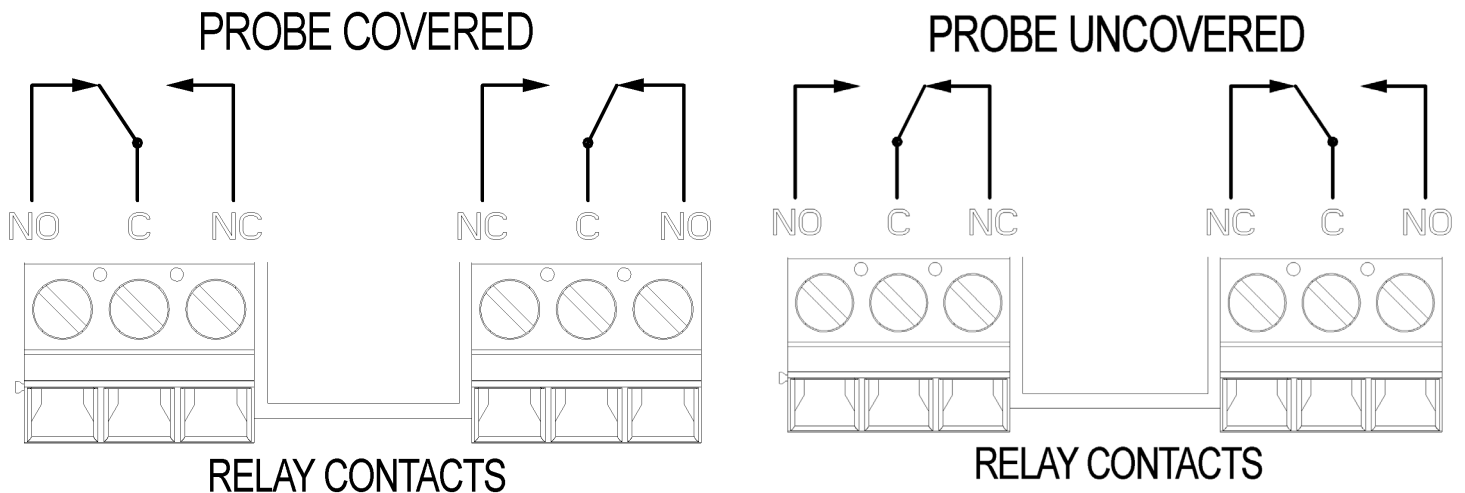

6.0 LIGHT RING STATUS INDICATION

The visual LED array indicates the status of the sensor. The 3 statuses are:

Probe uncovered:	Rotating GREEN LED
Probe covered:	Solid RED LEDs
Loss of input power:	LEDs OFF

8.0 REMOTE ELECTRONICS INSTALLATION

In some applications, such as excessive vibration or ambient temperatures above +140° F, it may be necessary to locate the electronic circuit board away from the vibrating rod. In these applications, a separate remote enclosure is used to mount the circuit board, and a special cable with individually shielded conductors is used to interconnect the circuit board to the vibrating probe unit. The remote electronics option is available for the VRX21, VRX31, VRX41, VRX51, VRX61, and VRX71 vibrating probes.

Figure 6 shows the mounting hole locations for the remote electronics enclosure. The interconnecting cable connections are also shown in Figure 6. The input power is supplied to the remote electronics and the special individually shielded conductor cable is routed between the remote electronics and the vibrating probe. The interconnect cable will have a wire connecting terminal “T” on the remote board to terminal “T” in the vibrating probe; terminal “R” on the remote board to terminal “R” in the vibrating probe; and signal ground on the remote board to signal ground in the vibrating probe.

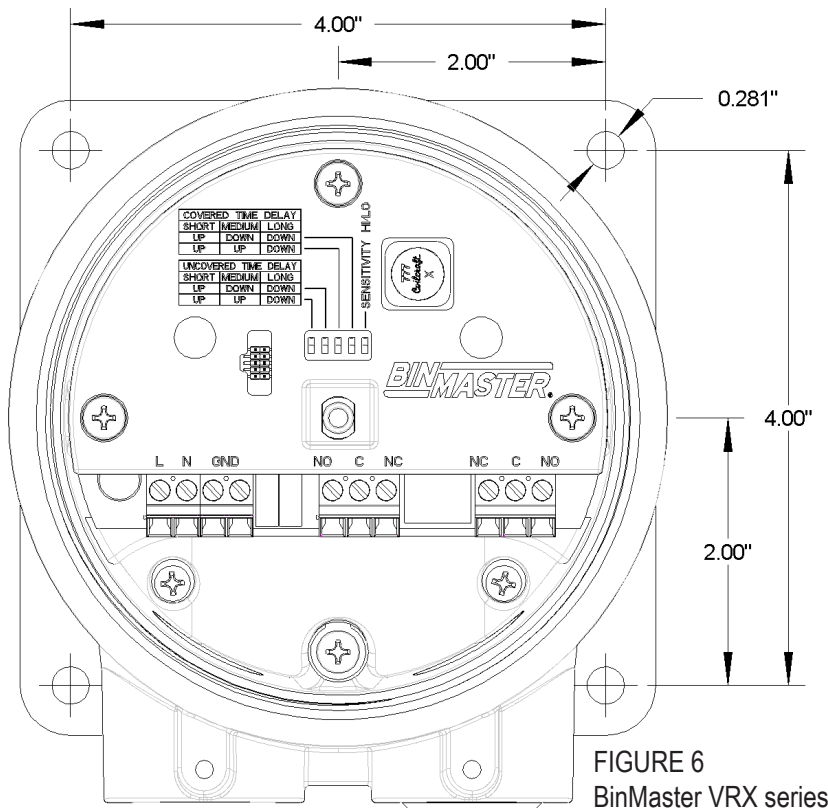
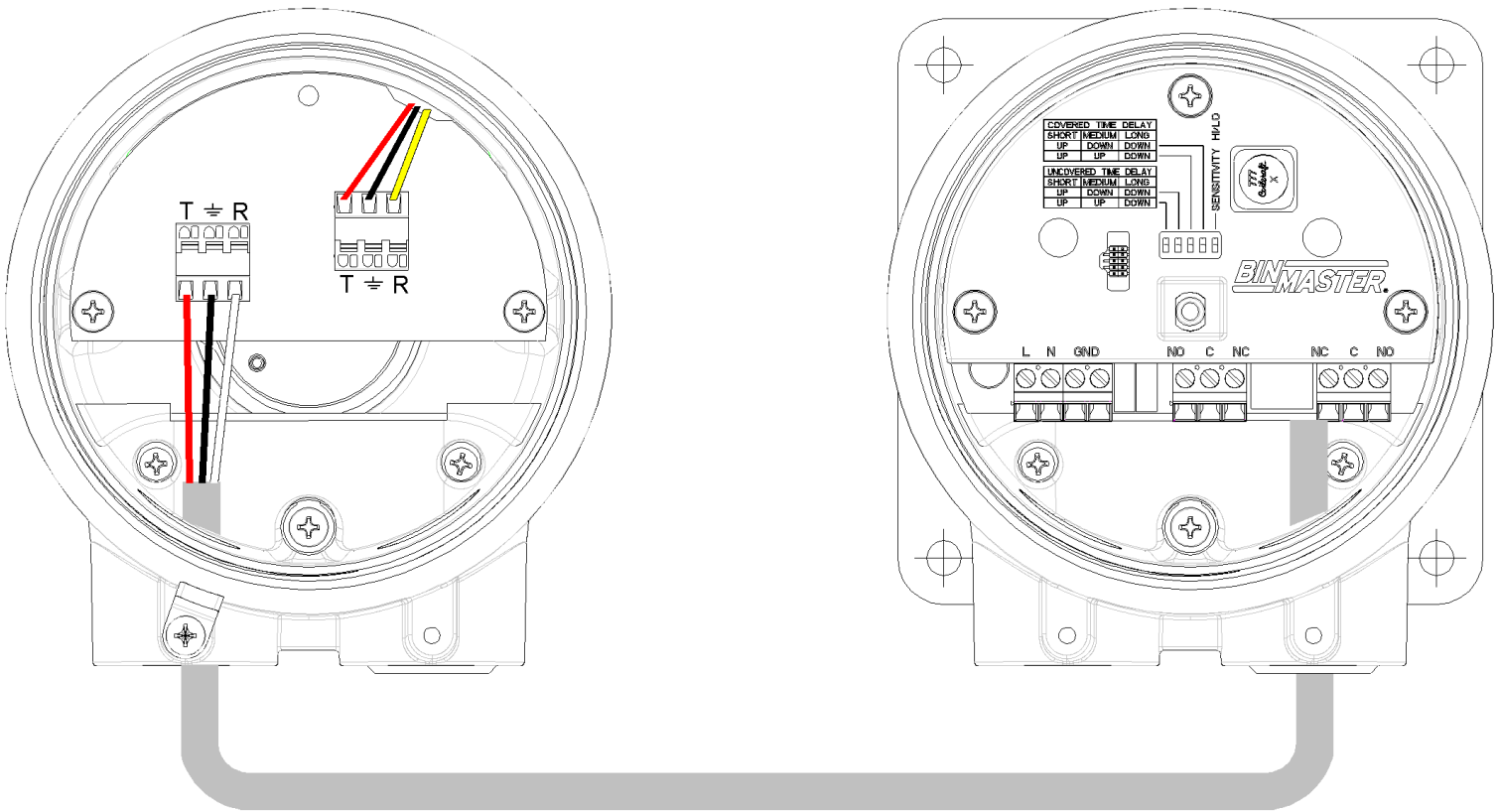

FIGURE 6
BinMaster VRX series
mounting hole locations



9.0 TERMS AND CONDITIONS - WARRANTY

Refer to the official terms and conditions - warranty found here:

<https://www.binmaster.com/terms-conditions>

9.1 CUSTOMER SERVICE & TECH SUPPORT

BinMaster's toll-free Customer Service phone number is (800) 278-4241. Call the Technical Service Department for support 8 a.m.-5 p.m., Monday through Friday, Central Time. International customers call (402) 434-9100 or techsupport@binmaster.com. More at support.binmaster.com.

10.0 DISPOSAL

This product contains recyclable materials and electronics that can be easily separated and recycled by specialized recycling companies. Consult local authorities for proper disposal locations.

This drawing is the property of Garner Industries. It is issued in confidence on the condition that it is to be returned on request and that it is not to be copied or reproduced in any way, or used in the manufacture of the subject matter thereof without the written consent of Garner Industries.

Division of Garner Industries / 7201 North 88th Street / Lincoln, NE 68507
 (402) 434-9102 / fax (402) 434-9144 / www.binmaster.com

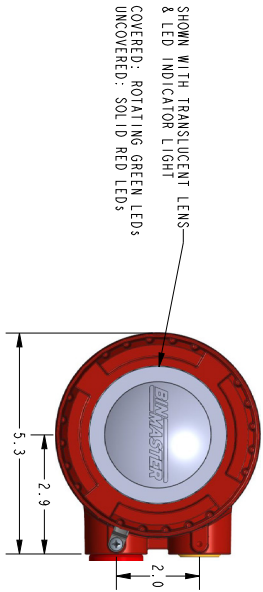

SHOWN WITH TRANSLUCENT LENS & LED INDICATOR LIGHT
 COVERED: ROTATING GREEN LED'S
 UNCOVERED: SOLID RED LED'S

SHOWN WITH 1-1/4 NPT PROBE

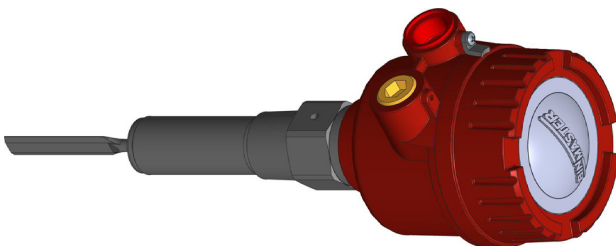

NOTE: REMOTE ELECTRONICS, SEDIMENT & HIGH TEMP. VERSIONS ARE ALSO AVAILABLE

ENCLOSURE BODY ROTATES 270° INDEPENDENTLY FROM VIBRATING ROD ALLOWING CONDUIT ENTRIES TO BE POSITIONED PROPERLY PER APPLICATION

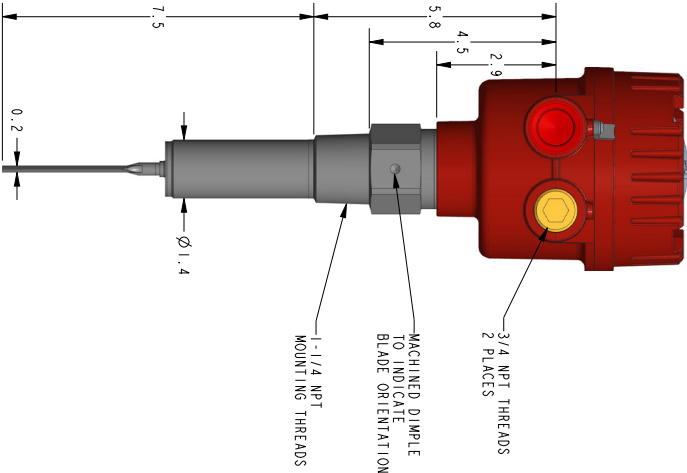
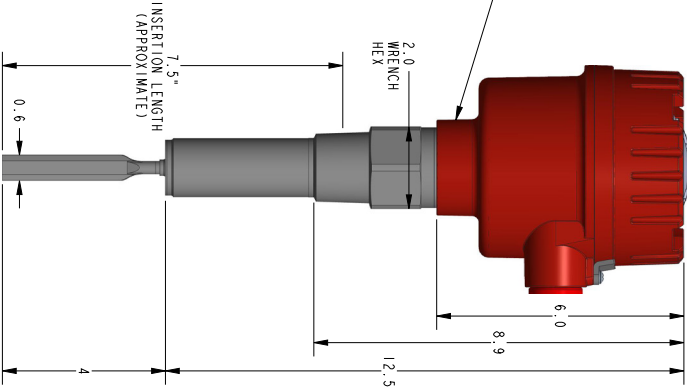

3/4 NPT THREADS 2 PLACES
 MACHINED DIMPLE TO INDICATE BLADE ORIENTATION
 1-1/4 NPT MOUNTING THREADS

TITLE: MTG DIM, VRX21 VIBRATING ROD

DWG No.: 418-0302

REVISION
SHEET 1 OF 3

The drawing is the property of Garner Industries. It is issued in confidence on the condition that it is to be returned on request and that it is not to be copied or reproduced in any way, or used in the manufacture of the subject matter thereof without the written consent of Garner Industries.
DIMENSIONS ARE IN INCHES UNLESS NOTED OTHERWISE

Division of Garner Industries / 7201 North 98th Street / Lincoln, NE 68507
(402) 434-9102 / fax (402) 434-9144 / www.binmaster.com

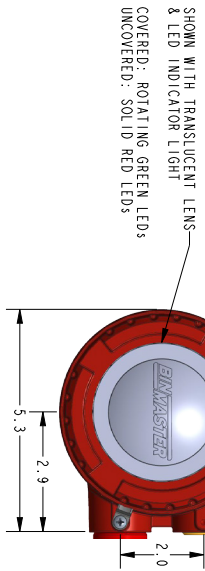

NOTE: REMOTE ELECTRONICS & CUSTOM EXTENDED VERSIONS UP TO 200cm ARE ALSO AVAILABLE

ENCLOSURE BODY ROTATES 270° INDEPENDENTLY FROM VIBRATING ROD ALLOWING CONDUIT ENTRIES TO BE POSITIONED PROPERLY PER APPLICATION

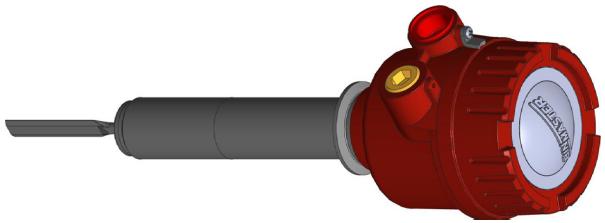
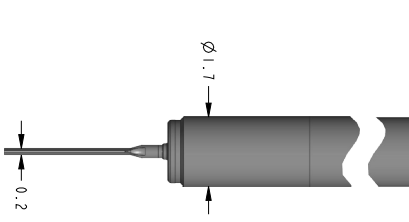
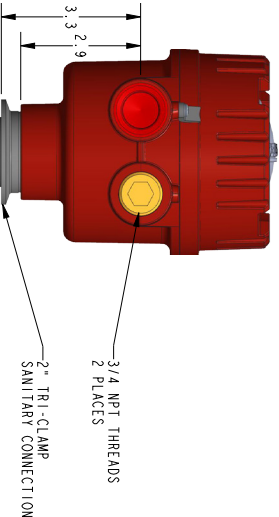
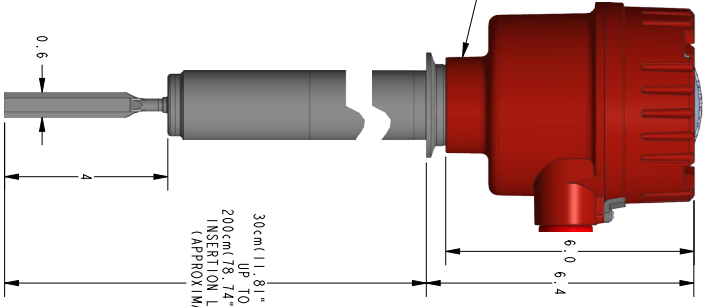

TITLE: MTG DIM, VRX31 VIBRATING ROD

DWG No.: 418-0303

REVISION
SHEET 1 OF 2

This drawing is the property of Garner Industries. It is issued in confidence on the condition that it is to be returned on request and that it is not to be copied or reproduced in any way, or used in the manufacture of the product depicted without the written consent of Garner Industries.

Division of Garner Industries / 7201 North 98th Street / Lincoln, NE 68907
 (402) 434-9102 / fax (402) 434-9144 | www.binmaster.com



SHOWN WITH TRANSLUCENT LENS & LED INDICATOR LIGHT
 COVERED: ROTATING GREEN LED'S
 UNCOVERED: SOLID RED LED'S

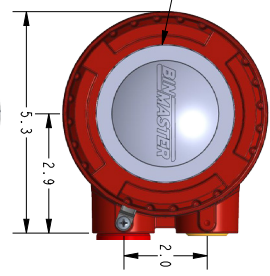

NOTE: REMOTE ELECTRONICS, SEDIMENT & HIGH TEMP. VERSIONS ARE ALSO AVAILABLE

ENCLOSURE BODY ROTATES 270° INDEPENDENTLY FROM INSERTING ROD ALLOWING CONDUIT ENTRIES TO BE POSITIONED PROPERLY PER APPLICATION

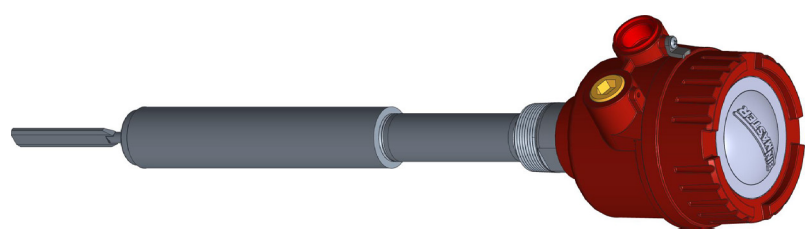
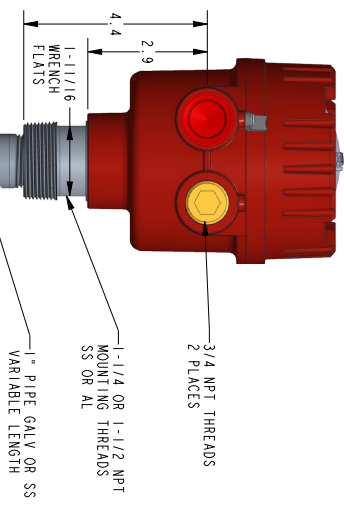
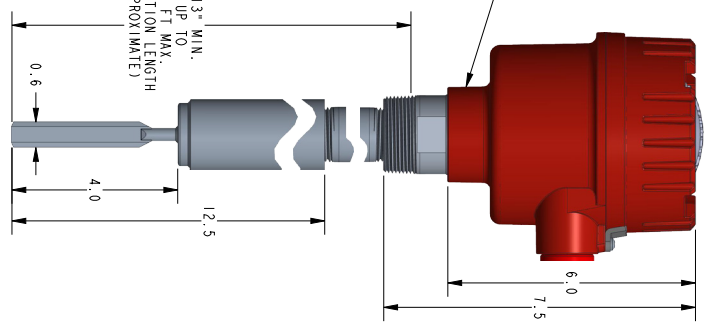

TITLE: MTG DIM, VRX41 VIBRATING ROD

DWG No.: 418-0304

REVISION
SHEET 1 OF 2

This drawing is the property of Garner Industries. It is issued in confidence on the condition that it is to be returned on request and that it not be copied or reproduced in any way, or used in the manufacture of the subject matter thereof without the written consent of Garner Industries.

Division of Garner Industries / 7201 North 98th Street / Lincoln, NE 68507
 (402) 434-9102 / fax (402) 434-9144 | www.binmaster.com

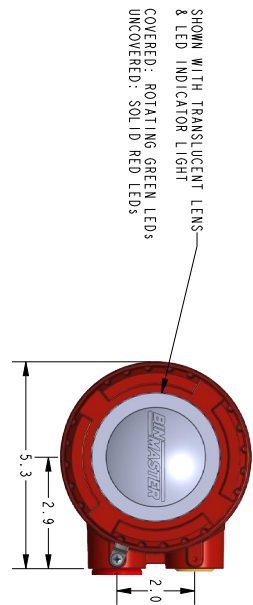

SHOWN WITH TRANSLUCENT LENS & LED INDICATOR LIGHT
 COVERED: ROTATING GREEN LEDS
 UNCOVERED: SOLID RED LEDS

NOTE: UP TO 19-1/2 FEET & REMOTE ELECTRONICS ARE ALSO AVAILABLE

ENCLOSURE BODY ROTATES 270° INDEPENDENTLY FROM VIBRATING ROD ALLOWING CONDUIT ENTRIES TO BE POSITIONED PROPERLY PER APPLICATION

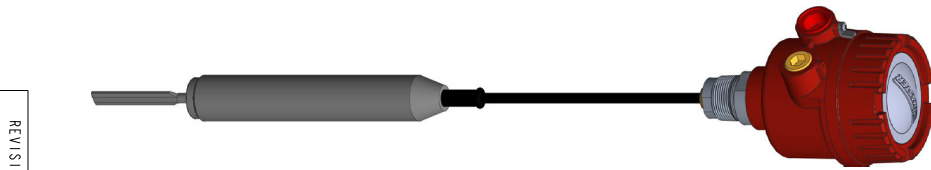
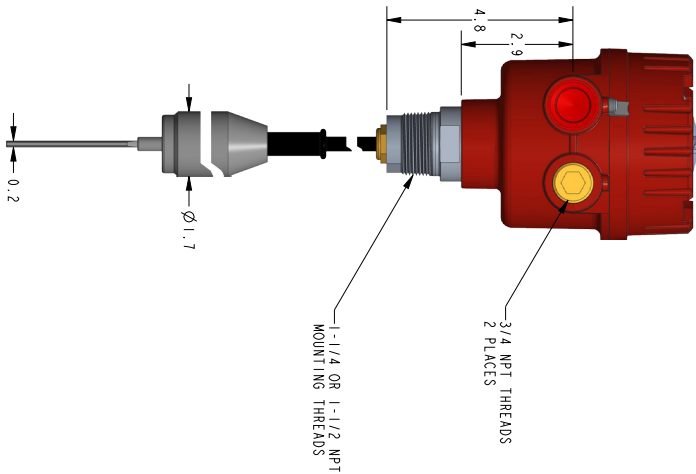
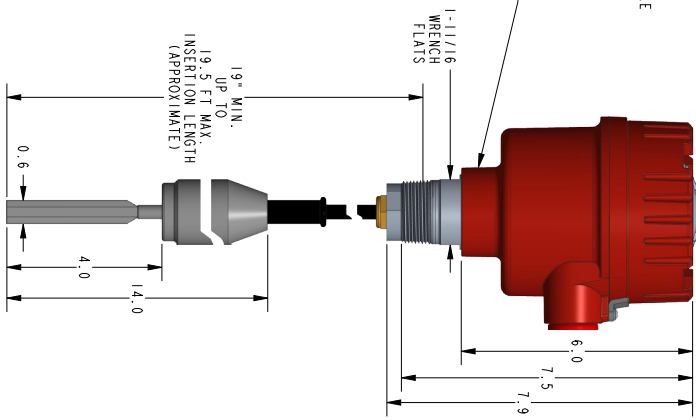

TITLE: MTG DIM, VRX51 VIBRATING ROD

DWG No.: 418-0305

REVISION
SHEET 1 OF 2

This drawing is the property of Garner Industries. It is issued in confidence on the condition that it is to be returned on request and that it not be reproduced, stored in a retrieval system, or used in the manufacture of the subject machinery or without the written consent of Garner Industries.

Division of Garner Industries / 7201 North 98th Street / Lincoln, NE 68607
 (402) 434-9102 / fax (402) 434-9144 | www.binmaster.com

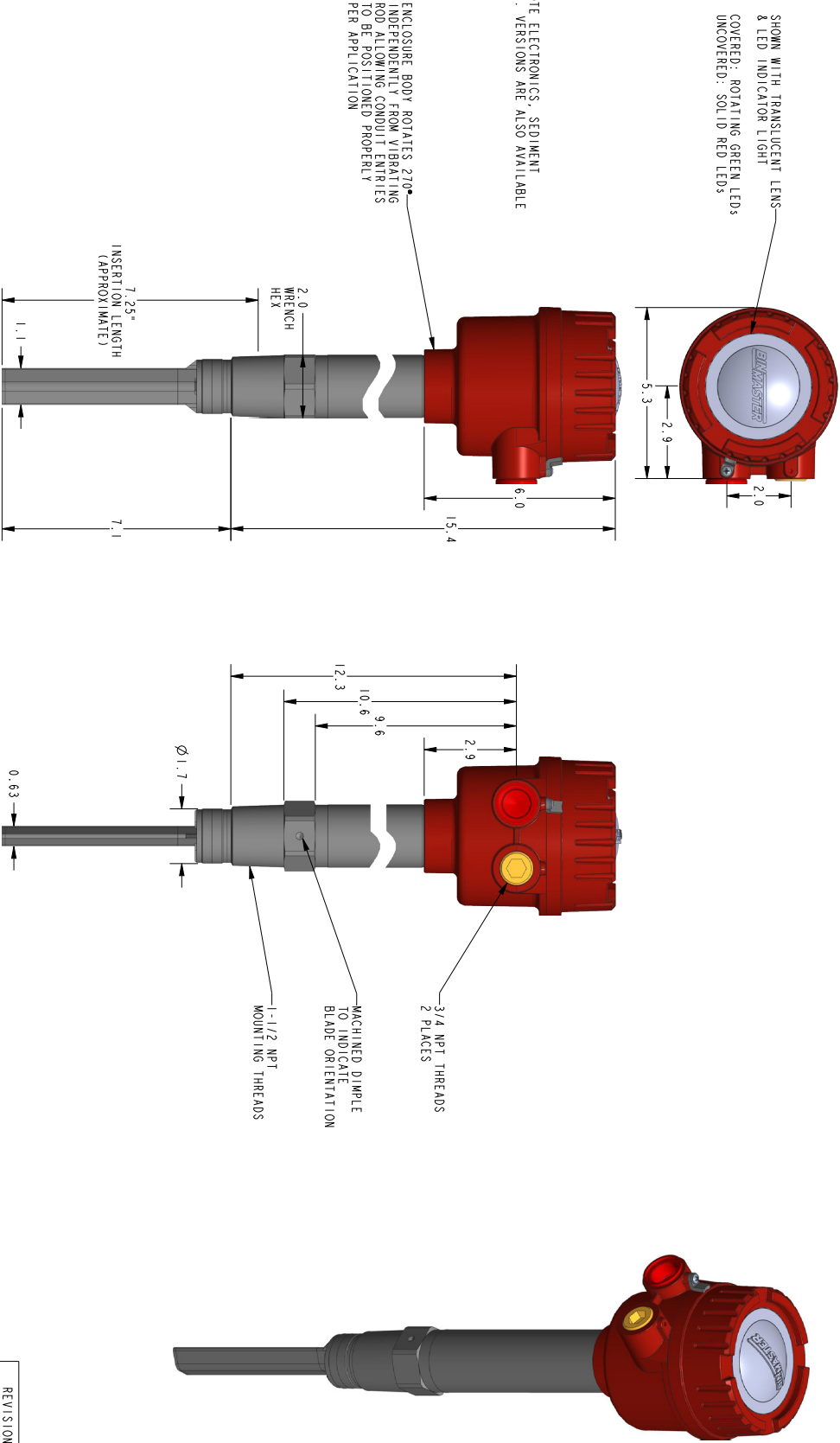

TITLE: MTG DIM, VRX61 VIBRATING ROD

DWG No.: 418-0306

REVISION
SHEET 1 OF 2

This drawing is the property of Gammer Industries. It is issued in confidence on the condition that it is to be returned on request and that it is not to be copied or reproduced in any way, or used in the manufacture of the subject matter thereof without the written consent of Gammer Industries.

Division of Gammer Industries / 7201 North 98th Street / Lincoln, NE 68507
 (402) 434-8102 / fax (402) 434-9144 / www.binmaster.com

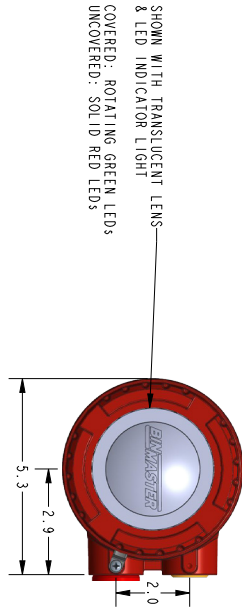

SHOWN WITH TRANSLUCENT LENS & LED INDICATOR LIGHT
 COVERED: ROTATING GREEN LED'S
 UNCOVERED: SOLID RED LED'S

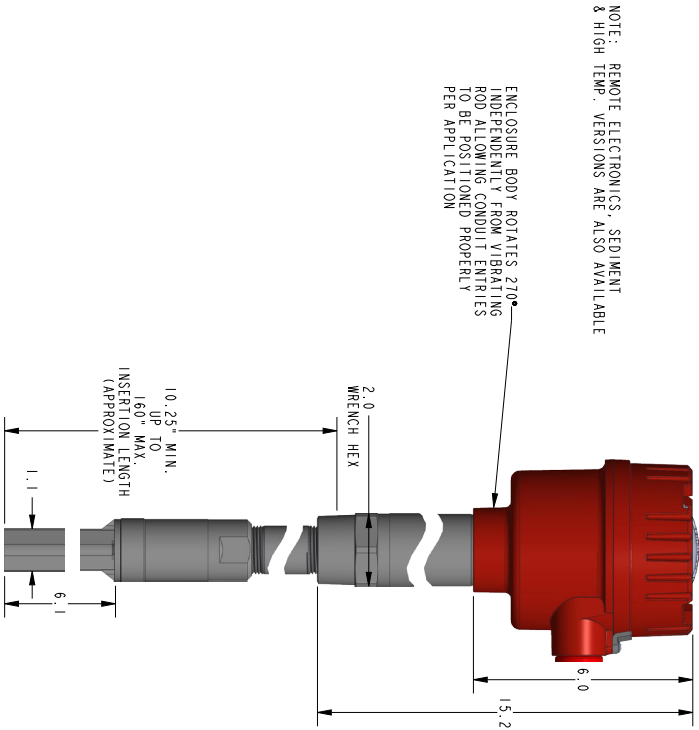

NOTE: REMOTE ELECTRONICS, SEDIMENT & HIGH TEMP. VERSIONS ARE ALSO AVAILABLE

ENCLOSURE BODY ROTATES 210° INDEPENDENTLY FROM VIBRATING ROD ALLOWING CONDUIT ENTRIES TO BE POSITIONED PROPERLY PER APPLICATION

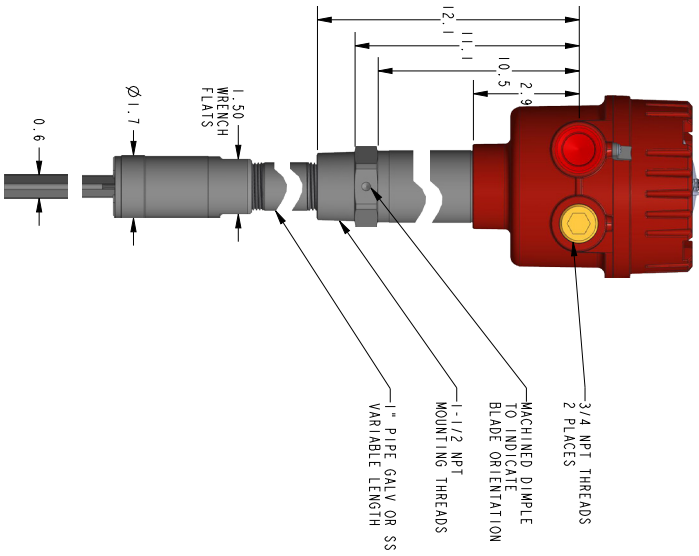

3/4 NPT THREADS
 2 PLACES
 MACHINED DIMPLE TO INDICATE BLADE ORIENTATION
 1-1/2 NPT MOUNTING THREADS
 1" PIPE GALV OR SS VARIABLE LENGTH
 1.50 WRENCH FLATS
 Ø 1.7

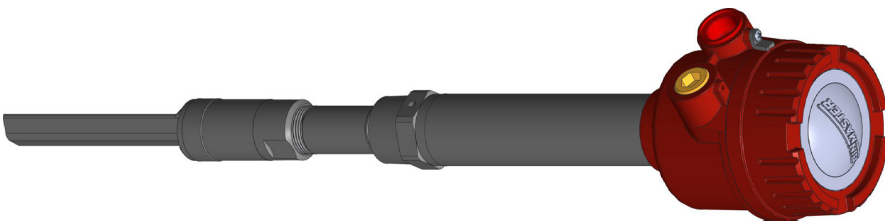

TITLE: MTG DIM, VRX71 VIBRATING ROD

DWG No.: 418-0307

REVISION
SHEET 1 OF 2



BinMaster
Lincoln, NE 68508
United States of America

Phone: (402) 434-9102
Fax: (402) 434-9133
Email: info@binmaster.com
www.binmaster.com